



WWW.HSPUTELIDS.COM

1300 441 498

Part No: H18-1

Fitting Time: 45mins



TOYOTA HILUX

HSP TAIL LOCK

FITTING INSTRUCTIONS

—GENERAL NOTES

- Read through the fitting instructions prior to installation of accessory.
- Ensure all recyclable components and packaging are discarded and recycled following local recycling regulations.
- Safely store and protect any removed vehicle components.

—SAFETY NOTES

- Check that all work practices comply with safety standards.
- Please wear appropriate clothing and use safety equipment.

—FITTING TIME



45mins

—PARTS SUPPLIED

Part Description	Part Number	Quality/ Length	CHECK LIST
TAIL LOCK ASSEMBLY			
Main Bracket	H18-A	1	
Eyelet	H18-B	1	
Actuator	ACT-01	1	
Wiring	CL-LOOM-LONG	1	
Patch Wiring	H-PATCH	1	
FASTENERS			
Actuator Screws	36	2	
Push on Clips	41	1	
OTHER			
Cable Ties		5	
Fitting Instruction		1	

— STEP 1 —

Fit Eyelet into actuator striker.

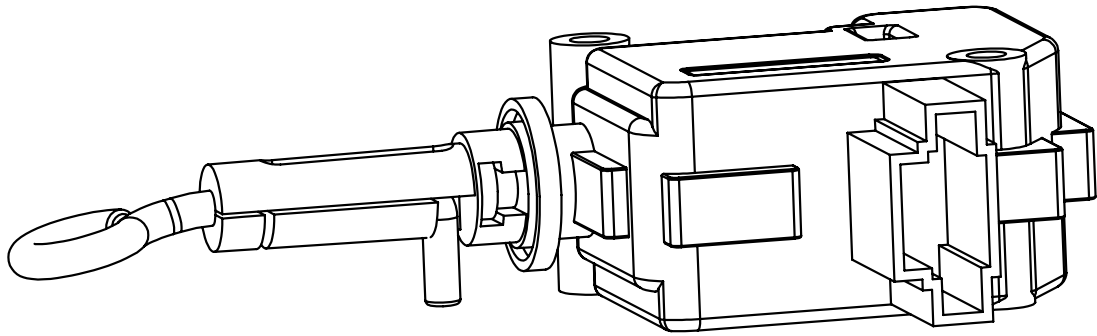

— STEP 2 —

Assemble the actuator to the TailLock bracket.

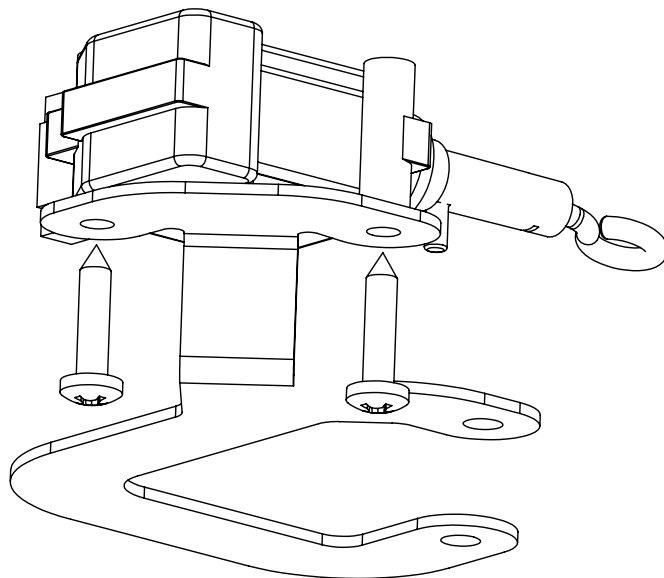

— STEP 3 —

Remove tail gate cover.

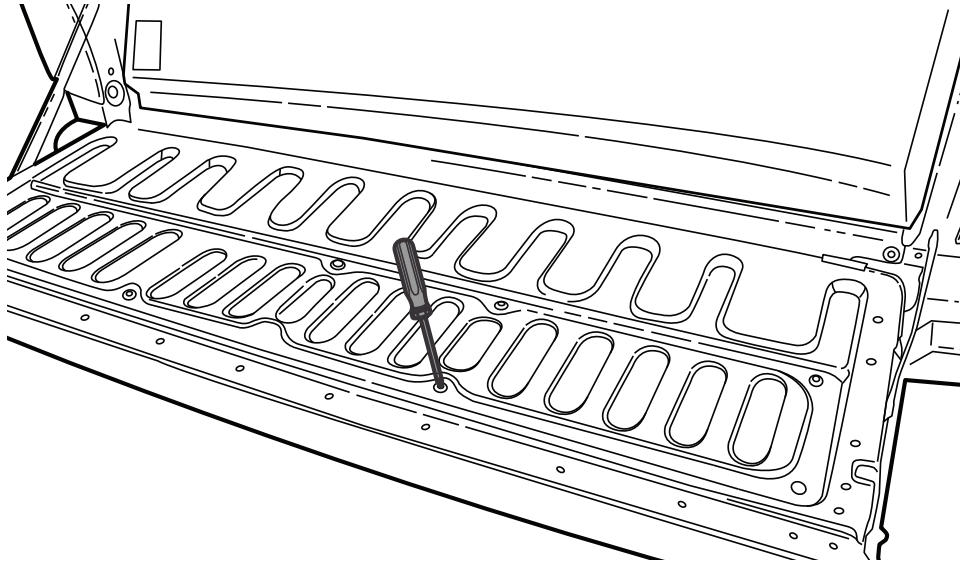

— STEP 4 —

Remove arm rods (b)

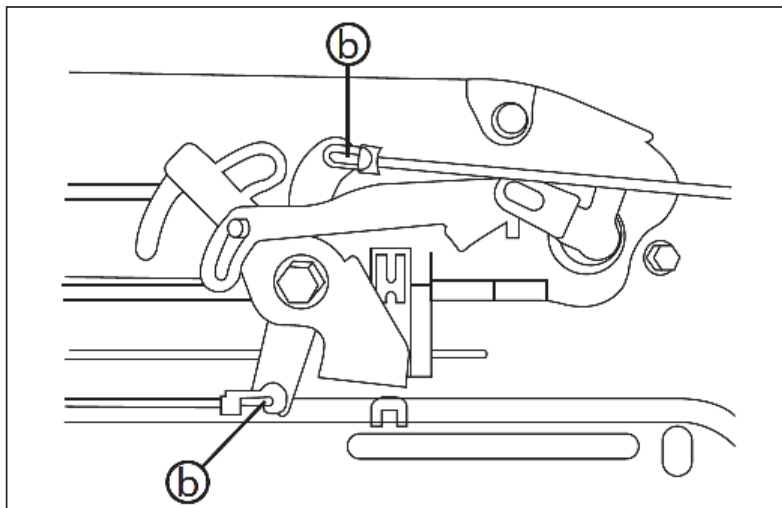

— STEP 5 —

Unfasten bolts (i)

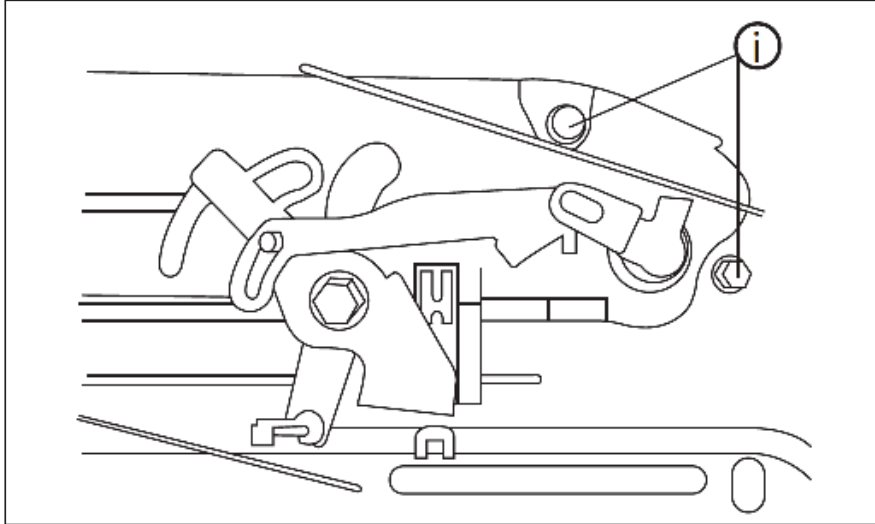

— STEP 6 —

Place TailLock assembly as shown and fasten bolts (i). Fit push on clip (b) as shown.

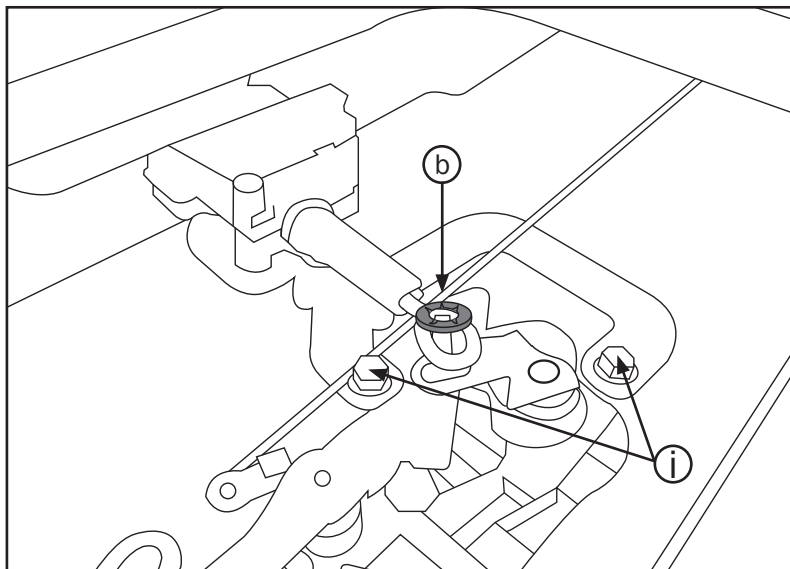

— STEP 7 —

- 1) Plug CL- Loom-long wiring to actuator end.
- 2) Route the CL- Loom-long harness (1) out of the tailgate and underneath the vehicle by feeding it into the original plastic cable protection.

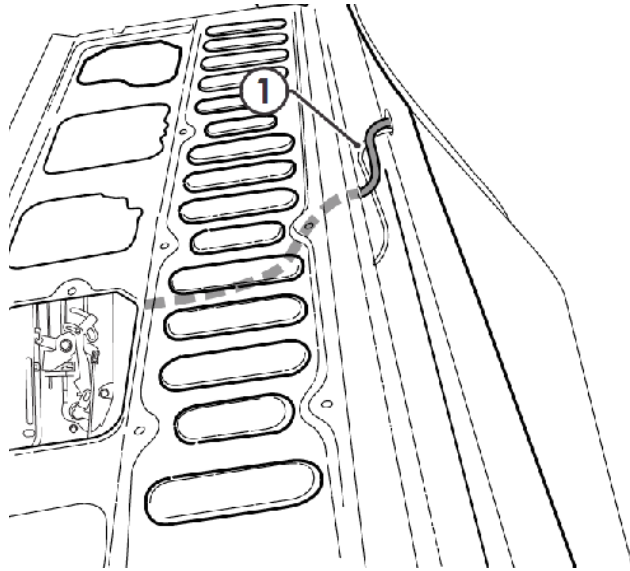

— STEP 8 —

Wiring diagram

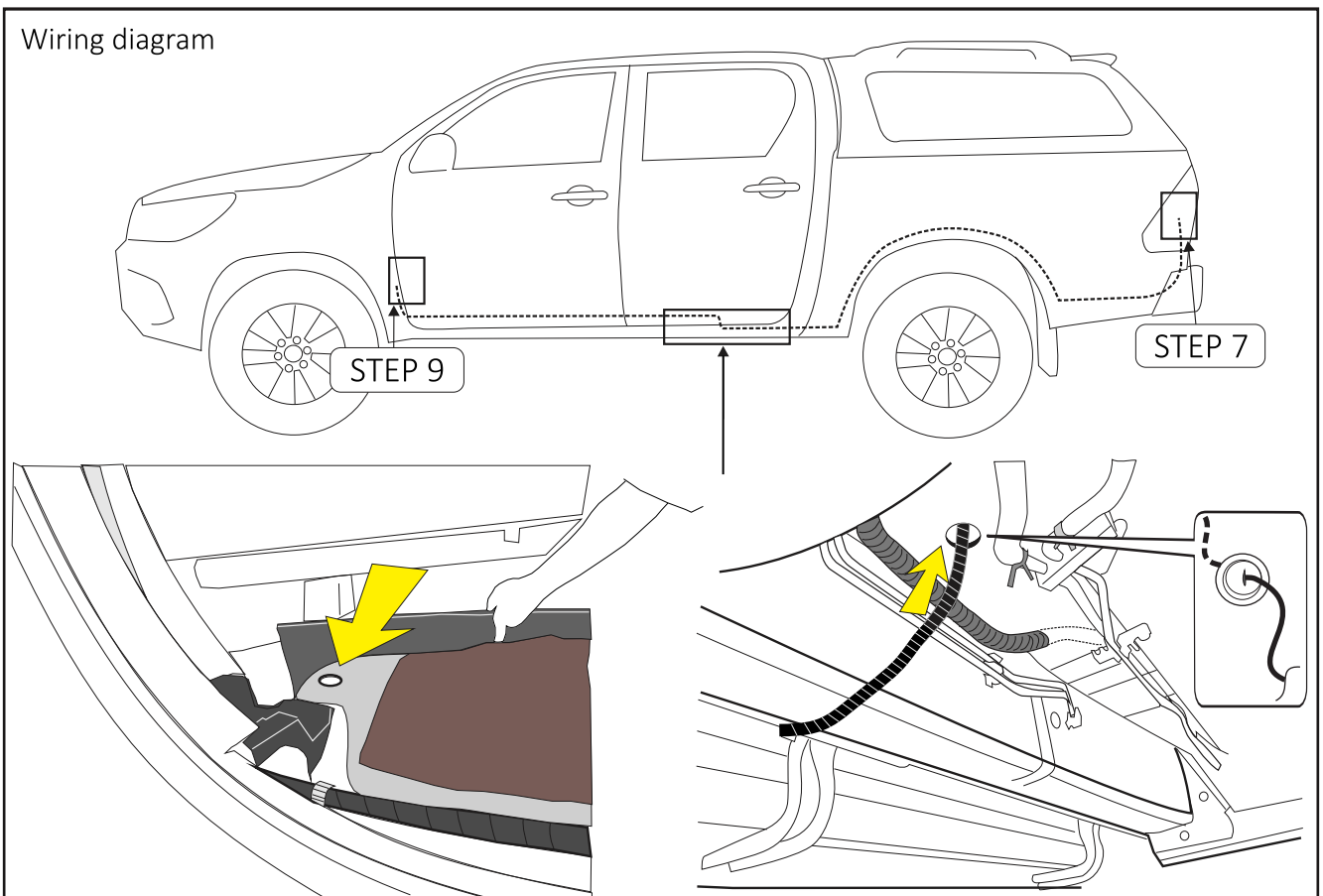

— STEP 9 —

At the front driver side foot well area:

- Remove front scuff plate (1)
- Remove the kick panel trim nut (2)
- Remove the kick panel (3)

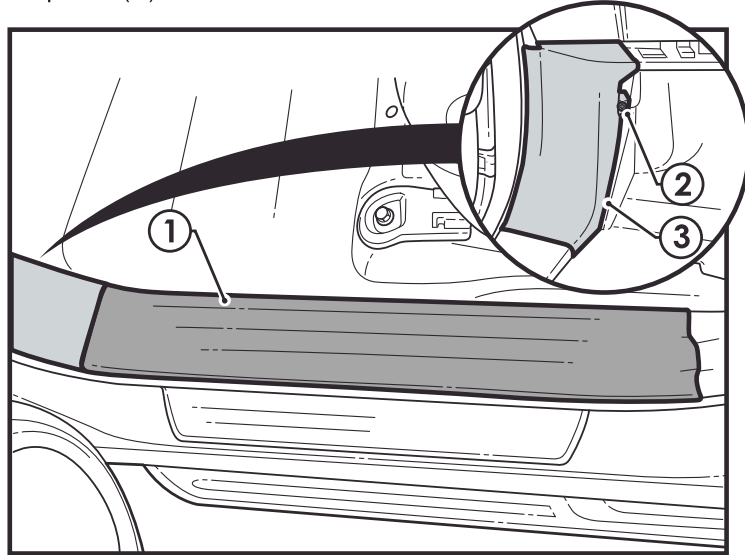

— STEP 10 —

Disconnect 20 way connector as indicated.

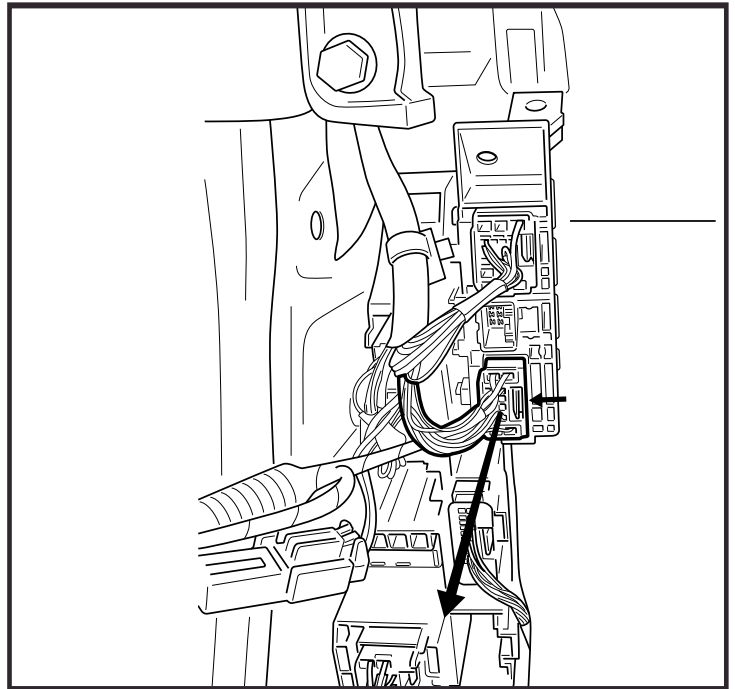

— STEP 11 —

1. Connect H-patch 20 way male connector to vehicle's female housing.
2. Connect vehicles 20 way connector to H-patch female housing.

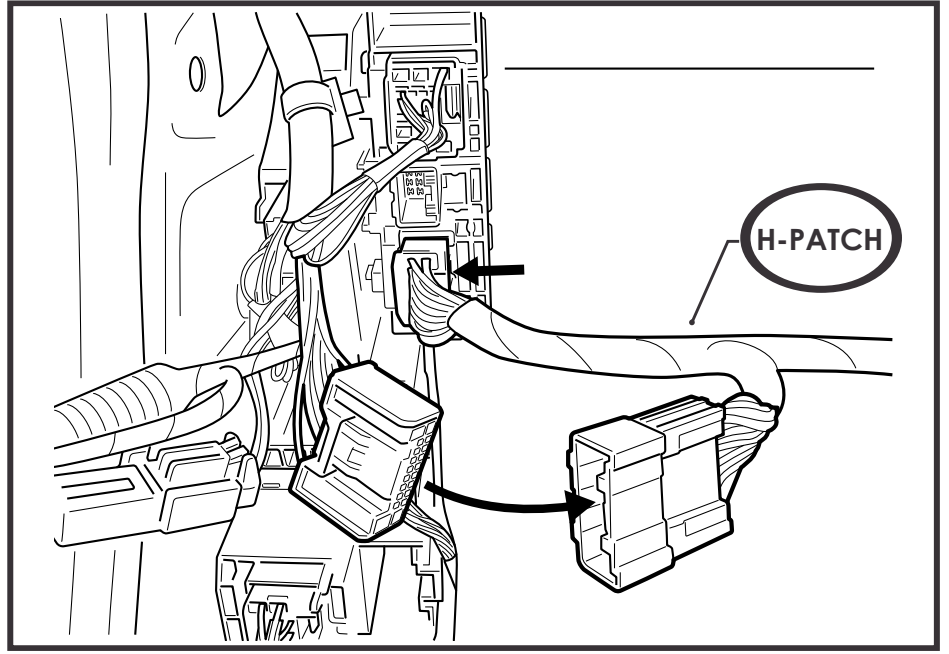

STEP 12

Connect H-PATCH loom to CL-LOOM-LONG

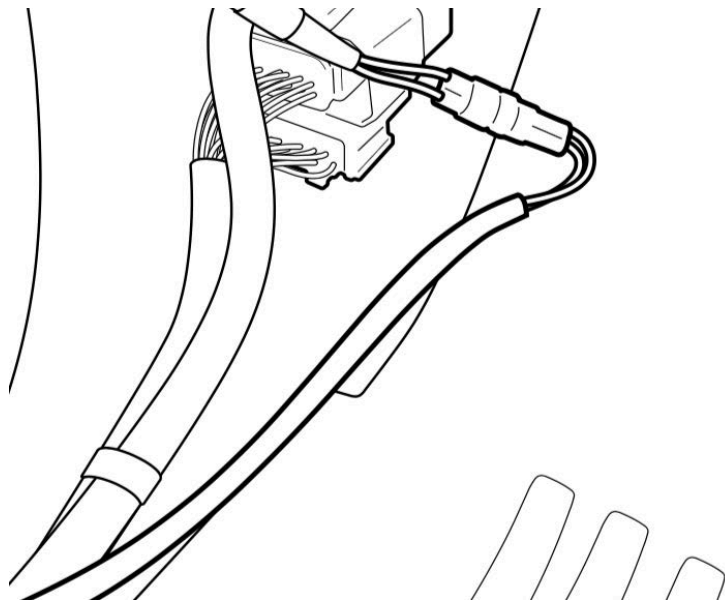

— STEP 15 —

Place and fasten tail gate cover.

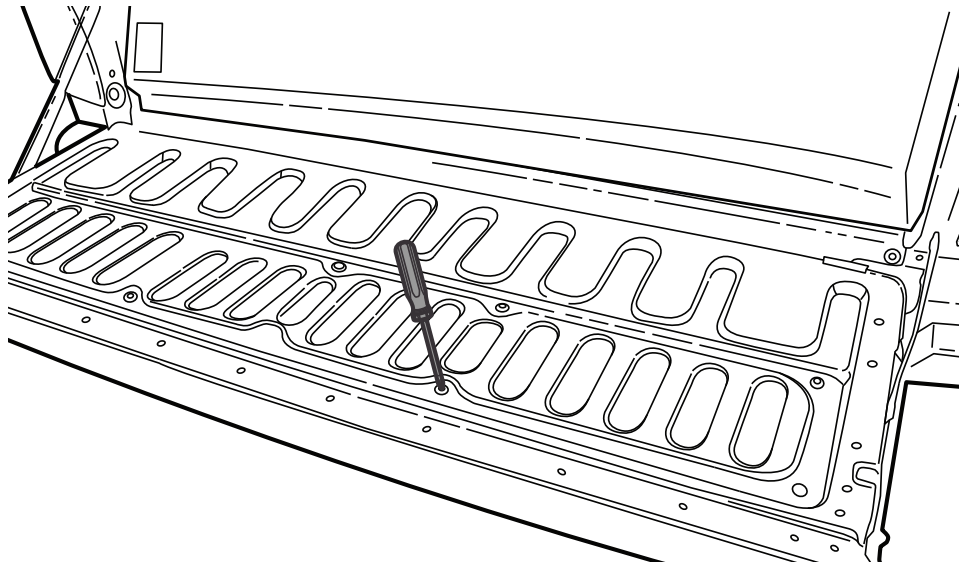

— FITTING COMPLETE —